

Structured Electronics Design

EE4109

Design exercise 2 and 3

A hearing loop system in CMOS18 technology

Anton J.M. Montagne

Application diagram

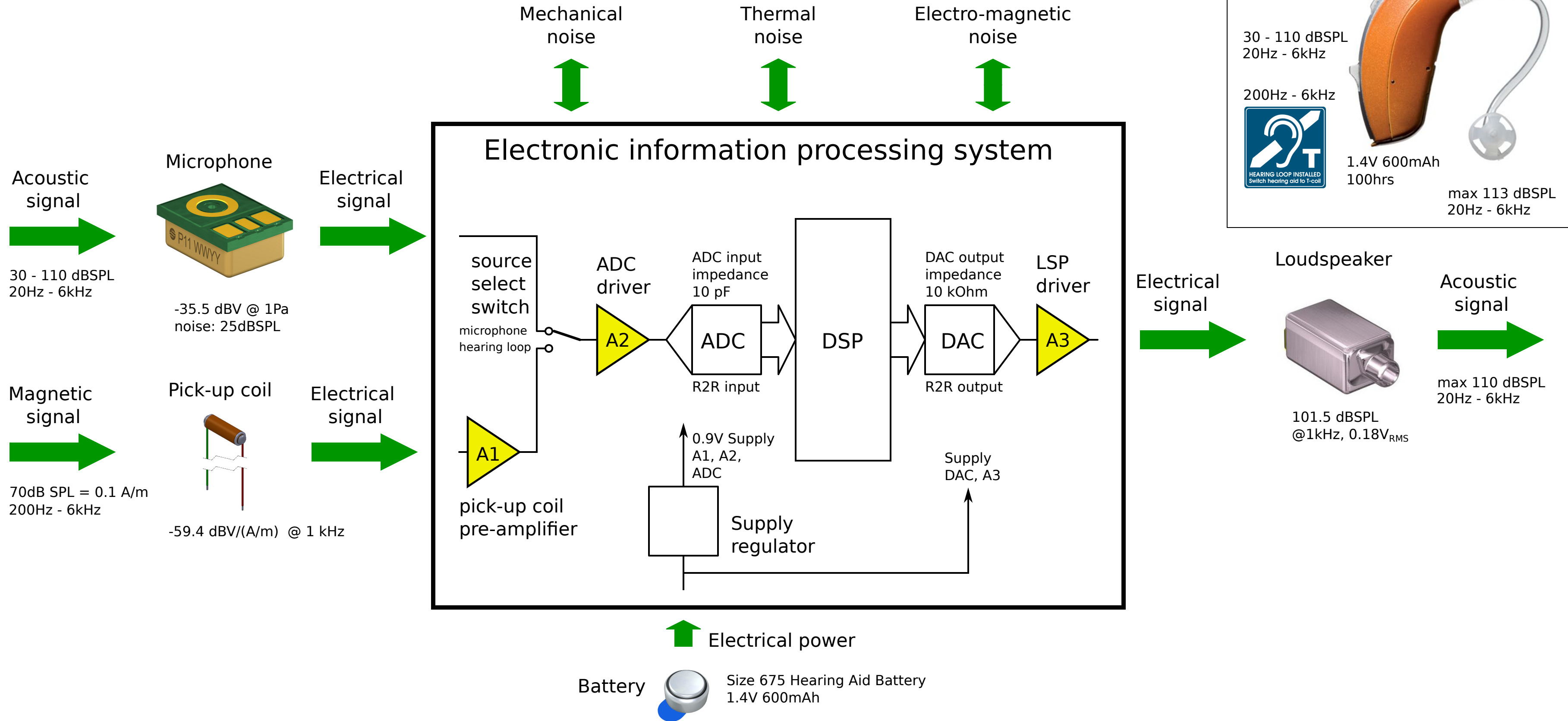

Design Exercise 2

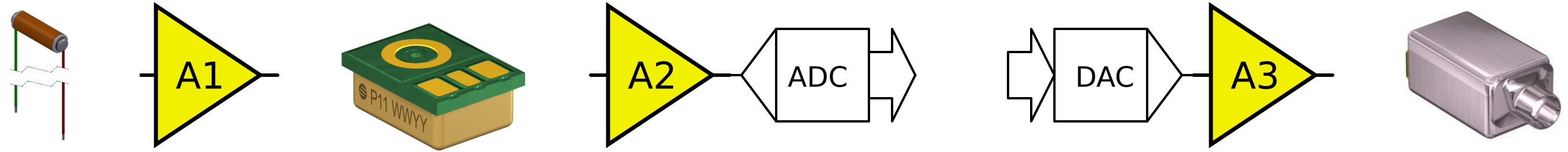

Input port	Floating / Grounded			
	DM Impedance			
	DM Voltage range			
	CM Voltage range			
Output port	Floating / Grounded			
	DM Impedance			
	CM Impedance			
	DM Voltage range			
	DM Current range			
Power port	Voltage range			
	Current range			
Transfer	Idealized Transfer			
	Frequency range			
	Input-referred noise			

Design Exercise 3

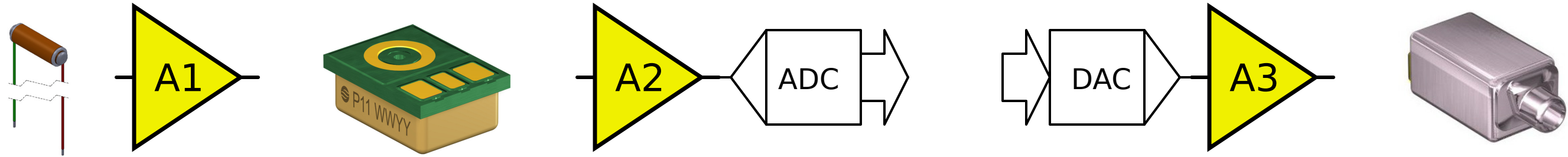

Feedback Structure A1

Feedback Structure A2

Feedback Structure A3