

**Coaxial Cable:  
It's not just a piece of wire.**

Prof. Carol Tanner  
For PHYS40441

# Coaxial Cable

Coaxial cable From Wikipedia, the free encyclopedia

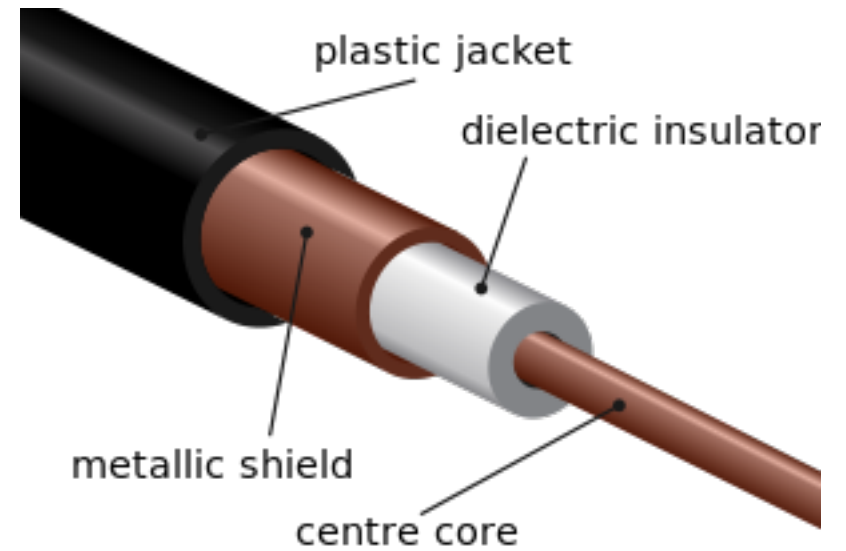
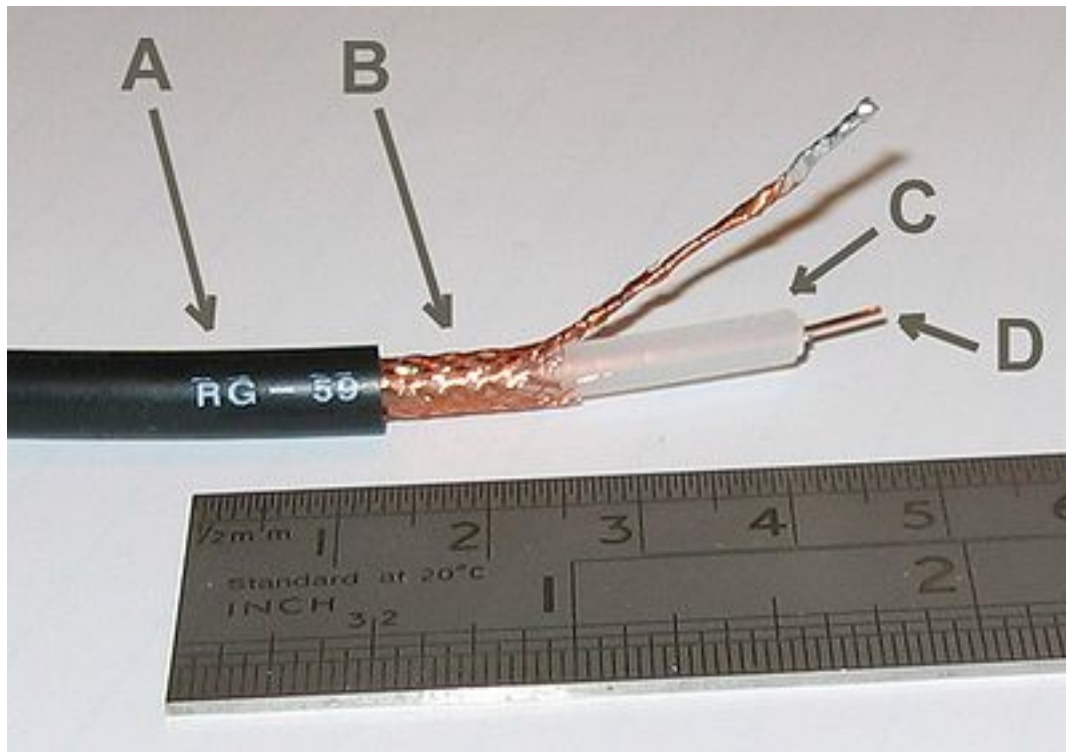

# Capacitance and Inductance per Unit Length

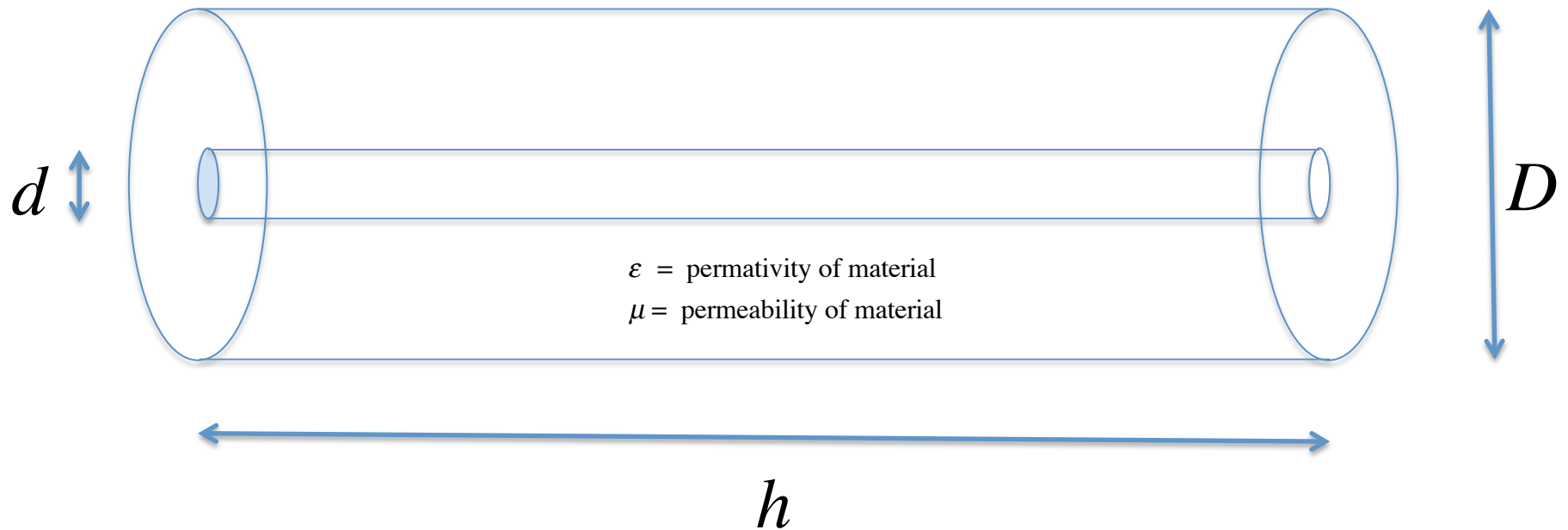

$$\left(\frac{C}{h}\right) = \frac{2\pi\epsilon}{\ln(D/d)} = \frac{2\pi\epsilon_0\epsilon_r}{\ln(D/d)}$$

Typically derived in your  
basic physics text.

$$\left(\frac{L}{h}\right) = \frac{\mu}{2\pi} \ln(D/d) = \frac{\mu_0\mu_r}{2\pi} \ln(D/d)$$

From Wikipedia, the  
free encyclopedia

# Schematic Representation

Coaxial cable From Wikipedia, the free encyclopedia

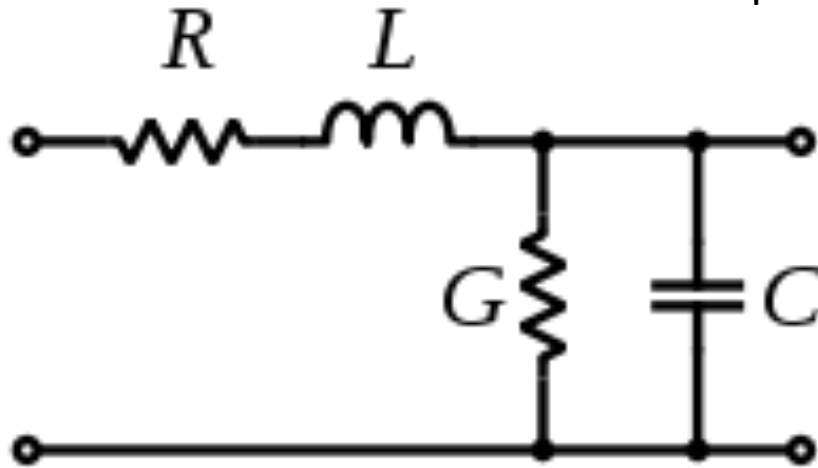

$L$ =total inductance  
 $C$ = total capacitance  
 $R$ = total resistance (small  $\rightarrow$  zero)  
 $G$ = total leakage resistance  
(very large  $\rightarrow$  infinite)

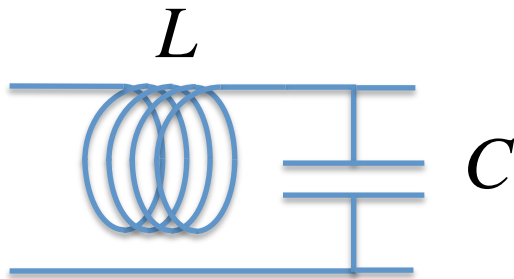

Simplified Schematic

This is not a very good model of a transmission line.

# Reminders from Basic Physics Courses

$$V_{drop} = RI$$

$$V_{drop} = \frac{Q}{C}$$

$$V_{drop} = L \frac{dI}{dt}$$

For AC circuits:

$$Z_R = R$$

$$Z_C = \frac{1}{j\omega C}$$

$$Z_L = j\omega L$$

$$V = Z I$$

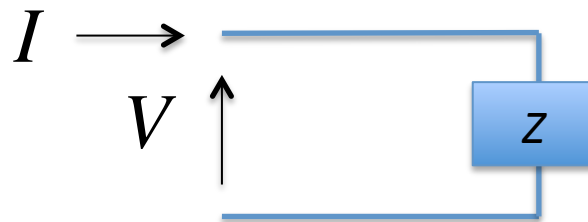

$$Z = \frac{V}{I}$$

# Derive the Capacitance of a Cylinder

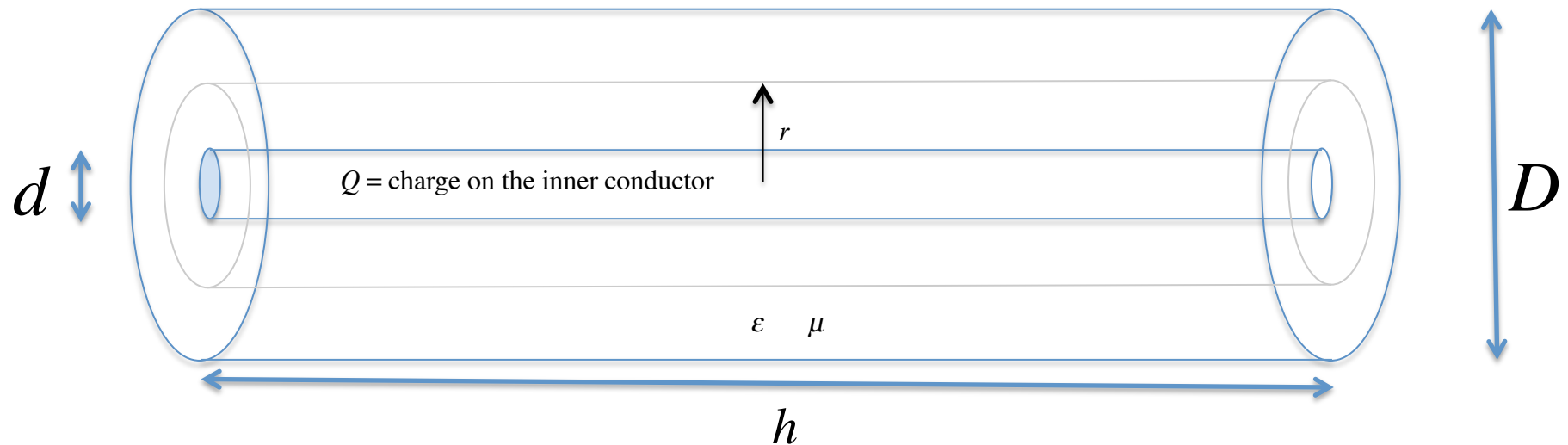

Used Gauss' Law and an imaginary surface to calculate the E field in the cylinder.

$$\int \vec{E} \cdot d\vec{a} = \frac{Q}{\epsilon}$$

$$E2\pi rh = \frac{Q}{\epsilon}$$

$$E = \frac{Q}{\epsilon 2\pi rh}$$

Voltage difference is the integral of the E field.

$$V = \int_{r_1}^{r_2} E dr = \frac{Q}{\epsilon 2\pi h} \int_{d/2}^{D/2} \frac{1}{r} dr = \frac{Q}{\epsilon 2\pi h} [\ln(D/2) - \ln(d/2)] = \frac{Q}{\epsilon 2\pi h} \ln\left(\frac{D}{d}\right)$$

$$Q = CV$$

$$C = \frac{Q}{V} = \frac{2\pi\epsilon h}{\ln\left(\frac{D}{d}\right)}$$

$$\frac{C}{h} = \frac{2\pi\epsilon}{\ln(D/d)}$$

# Derive the Inductance of a Cylinder

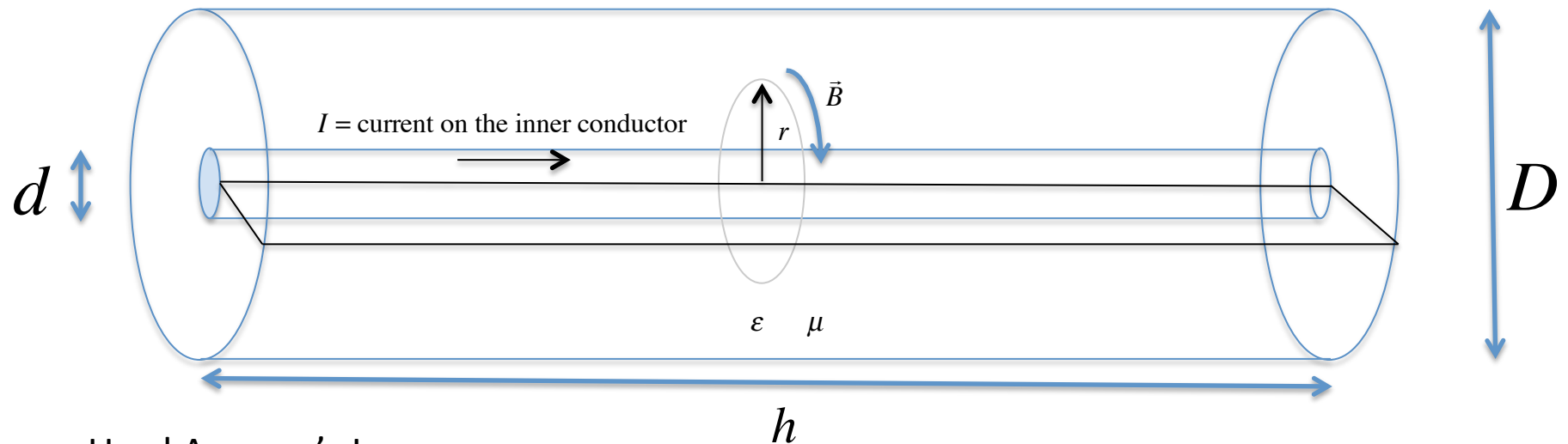

- Used Ampere's Law and an imaginary path to calculate the B field in the cylinder.

$$\oint \vec{B} \cdot d\vec{\ell} = \mu I$$

$$B 2\pi r = \mu I$$

$$B = \frac{\mu I}{2\pi r}$$

- Determine the flux through the imaginary loop.

$$\phi = \int_{r_1}^{r_2} \vec{B} \cdot d\vec{a} = \int_{d/2}^{D/2} \frac{\mu I}{2\pi r} h dr = \frac{\mu I}{2\pi} h [\ln(D/2) - \ln(d/2)] = \frac{\mu I}{2\pi} h \ln\left(\frac{D}{d}\right)$$

- Inductance is proportional to the induced EMF for a change in current.

$$V_{drop} = -EMF = \frac{d\phi}{dt} = L \frac{dI}{dt} = \left[ h \frac{\mu}{2\pi} \ln\left(\frac{D}{d}\right) \right] \frac{dI}{dt}$$

$$L = h \frac{\mu}{2\pi} \ln\left(\frac{D}{d}\right)$$

$$\frac{L}{h} = \frac{\mu}{2\pi} \ln\left(\frac{D}{d}\right)$$

# Characteristic Impedance of a Coaxial Cable

$$Z_0 = \sqrt{\frac{L/h}{C/h}} = \sqrt{\frac{L}{C}} = \sqrt{\frac{\frac{\mu}{2\pi} \ln(D/d)}{2\pi\epsilon}} = \frac{1}{2\pi} \sqrt{\frac{\mu}{\epsilon} \ln(D/d)}$$

$$v = \frac{1}{\sqrt{\mu\epsilon}}$$

Speed of EM wave in a medium.

$$c = \frac{1}{\sqrt{\mu_0\epsilon_0}}$$

Speed of EM wave in a vacuum.

Index of Refraction

$$\frac{c}{v} = \frac{\frac{1}{\sqrt{\mu_0\epsilon_0}}}{\frac{1}{\sqrt{\mu\epsilon}}} = \sqrt{\frac{\mu}{\mu_0} \frac{\epsilon}{\epsilon_0}}$$



# Common Types

type ▾	impedance ohms ⚡	core ⚡	Dielectric Type ⚡	Dielectric VF ⚡	Dielectric in ⚡	Dielectric mm ⚡	OD in ⚡	OD mm ⚡	shields ⚡	comments ⚡	max attenuation @ 750 MHz dB/100 ft ⚡
RG-56/U	48	1.4859 mm					0.308	7.82	Dual braid shielded	Rated to 8000 volts, rubber dielectric	
RG-58/U	50	0.81 mm	PE	0.66	0.116	2.9	0.195	5.0	single	Used for radiocommunication and amateur radio, thin Ethernet (10BASE2) and NIM electronics, Loss 1.056 dB/m @ 2.4 GHz. Common. <sup>[19]</sup>	13.104 <sup>[16]</sup>
RG-59/U	75	0.64 mm	PE	0.66	0.146	3.7	0.242	6.1	single	Used to carry baseband video in closed-circuit television, previously used for cable television. In general, it has poor shielding but will carry an HQ HD signal or video over short distances. <sup>[20]</sup>	9.708 <sup>[16]</sup>
RG-59A/U	75	0.762 mm	PF	0.78	0.146	3.7	0.242	6.1	single	Similar physical characteristics as RG-59 and RG-59/U, but with a higher velocity factor.	8.9@700MHz <sup>[21]</sup>

# What it is the characteristic impedance of a transmission line?

We need a better model!

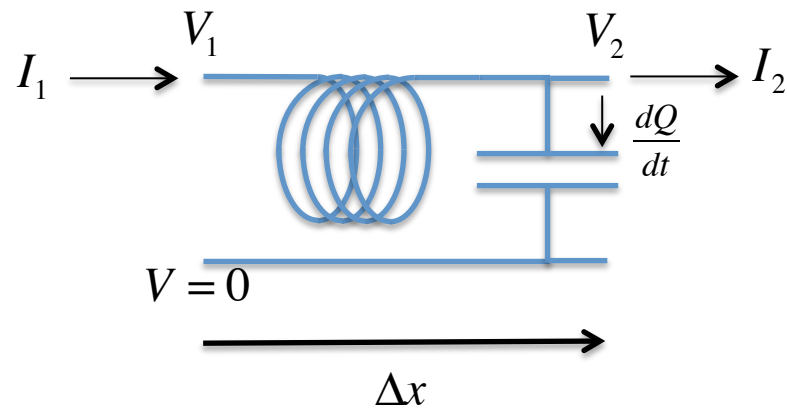
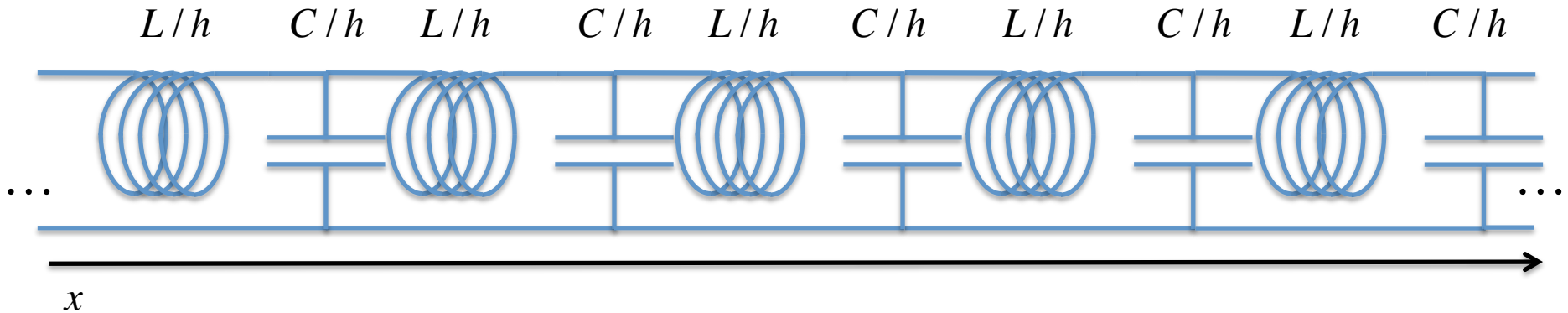

$$V_1 - V_2 = \frac{L}{h} \Delta x \frac{dI}{dt}$$

$$\Delta V = V(x_2) - V(x_1)$$

$$\frac{\Delta V}{\Delta x} = -\frac{L}{h} \frac{dI_1}{dt}$$

$$\lim_{\Delta x \rightarrow 0} \frac{\Delta V}{\Delta x} = \frac{\partial V}{\partial x} = -\frac{L}{h} \frac{dI}{dt}$$

1

$$I_1 - I_2 = \frac{dQ}{dt} = \frac{C}{h} \Delta x \frac{dV_2}{dt}$$

$$\Delta I = I(x_2) - I(x_1)$$

$$\frac{\Delta I}{\Delta x} = -\frac{C}{h} \frac{dV_2}{dt}$$

$$\lim_{\Delta x \rightarrow 0} \frac{\Delta I}{\Delta x} = \frac{\partial I}{\partial x} = -\frac{C}{h} \frac{dV}{dt}$$

2

# Two Coupled Diff. Eq.s

Solve for voltage and current.

$$1 \quad \frac{\partial V}{\partial x} = -\frac{L}{h} \frac{dI}{dt} \qquad 2 \quad \frac{\partial I}{\partial x} = -\frac{C}{h} \frac{dV}{dt}$$

$$\frac{\partial}{\partial x} \frac{\partial V}{\partial x} = -\frac{L}{h} \frac{d}{dt} \frac{\partial I}{\partial x} = -\frac{L C}{h h} \frac{d}{dt} \frac{dV}{dt}$$

Wave Equation

$$\frac{\partial^2 V}{\partial x^2} - \left( \frac{L C}{h h} \right) \frac{d^2 V}{dt^2} = 0$$

Traveling wave  
solution for V

$$V = A e^{i(kx - \omega t)}$$

$$k^2 = \omega^2 \frac{L C}{h h}$$

$$k = \pm \omega \sqrt{\frac{L C}{h h}}$$

$$\left| \frac{\omega}{k} \right| = v = \frac{1}{\sqrt{\frac{L C}{h h}}}$$

Find the current for a  
positive going wave.

$$\frac{dI}{dt} = -\frac{1}{L/h} \frac{\partial V}{\partial x} = -\frac{1}{L/h} ikA e^{i(kx - \omega t)}$$

$$I = \int \frac{dI}{dt} dt = -\frac{1}{L/h} ikA \int e^{i(kx - \omega t)} dt = \frac{1}{L/h} \frac{-ik}{-i\omega} A e^{i(kx - \omega t)} = \frac{1}{L/h} \sqrt{\frac{L C}{h h}} A e^{i(kx - \omega t)}$$

$$I(x, t) = \sqrt{\frac{C/h}{L/h}} A e^{i(kx - \omega t)}$$

# What voltage and current do we use to calculate the characteristic impedance?

The voltage and current at any particular point along the transmission line.

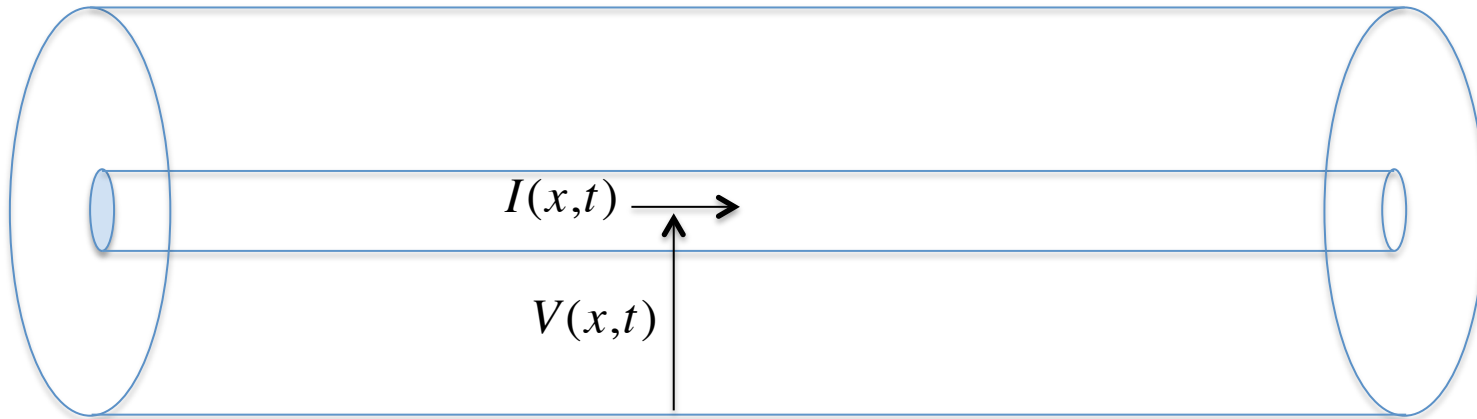

Assume  $V = 0$  on the outside conductor.

$$Z_0 = \frac{V(x,t)}{I(x,t)} = \frac{Ae^{i(kx-\omega t)}}{\sqrt{\frac{C}{L/h}} Ae^{i(kx-\omega t)}} = \sqrt{\frac{L/h}{C/h}} = \sqrt{\frac{L}{C}}$$

$$\left(\frac{C}{h}\right) = \frac{2\pi\epsilon}{\ln(D/d)} = \frac{2\pi\epsilon_0\epsilon_r}{\ln(D/d)}$$

$$\left(\frac{L}{h}\right) = \frac{\mu}{2\pi} \ln(D/d) = \frac{\mu_0\mu_r}{2\pi} \ln(D/d)$$

$$v = \frac{1}{\sqrt{\frac{L}{h} \frac{C}{h}}} = \frac{1}{\sqrt{\mu\epsilon}}$$

# Demonstration